

1/2, 1/3, 1/4-DUTY LCD CONTROLLER/DRIVER

The μ PD16431A is an LCD controller/driver that enables display of segment type LCDs of 1/2, 1/3, or 1/4 duty cycle. This controller/driver has 56 segment output lines of which eight can also be used as LED output lines. Because the LCD driver contained in the μ PD16431A has separate logic and power supply, up to 6.5 V of LCD drive voltage can be set. In addition, key source output lines for key scanning and key input data lines are also provided, so that the μ PD16431A is ideal for applications in the front panel of an automobile stereo system.

FEATURES

- Various display modes
 - 1/2 duty: 112 segment outputs or 96 segment outputs + 8 LED outputs
 - 1/3 duty: 168 segment outputs or 144 segment outputs + 8 LED outputs
 - 1/4 duty: 224 segment outputs or 192 segment outputs + 8 LED outputs
- Key scan circuit (key source outputs are shared with LCD driver outputs)
- Independent LCD driver power supply V_{LCD} (can be set to V_{DD} to 6.5 V)
- Serial data input/output (SCK, STB, DATA)
- On-chip oscillator incorporated
- Power-ON reset circuit

ORDERING INFORMATION

Part Number	Package
μ PD16431AGC-7ET	80-pin plastic QFP (0.65 pitch, 14 × 14)

BLOCK DIAGRAM

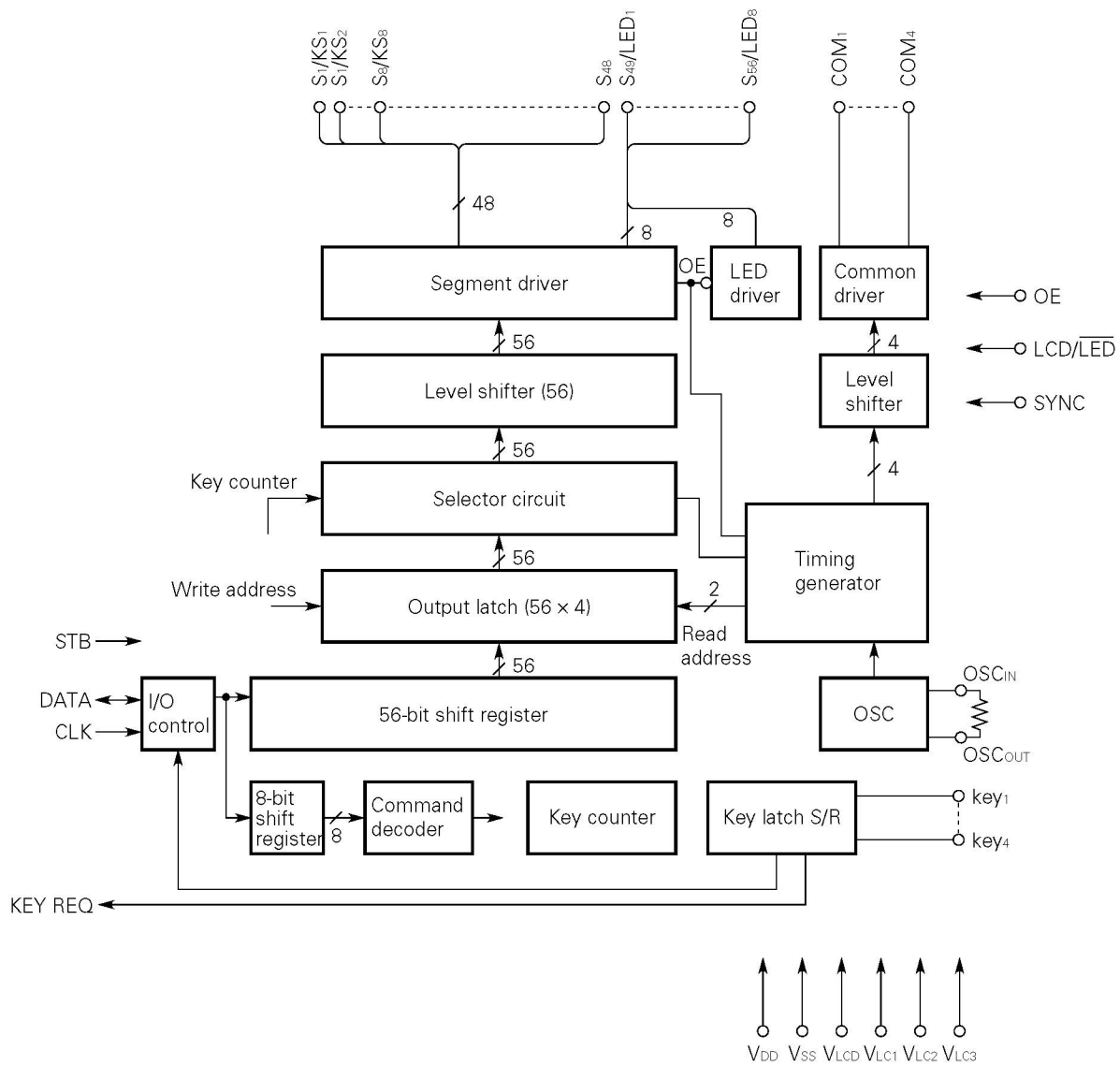

PIN CONFIGURATION

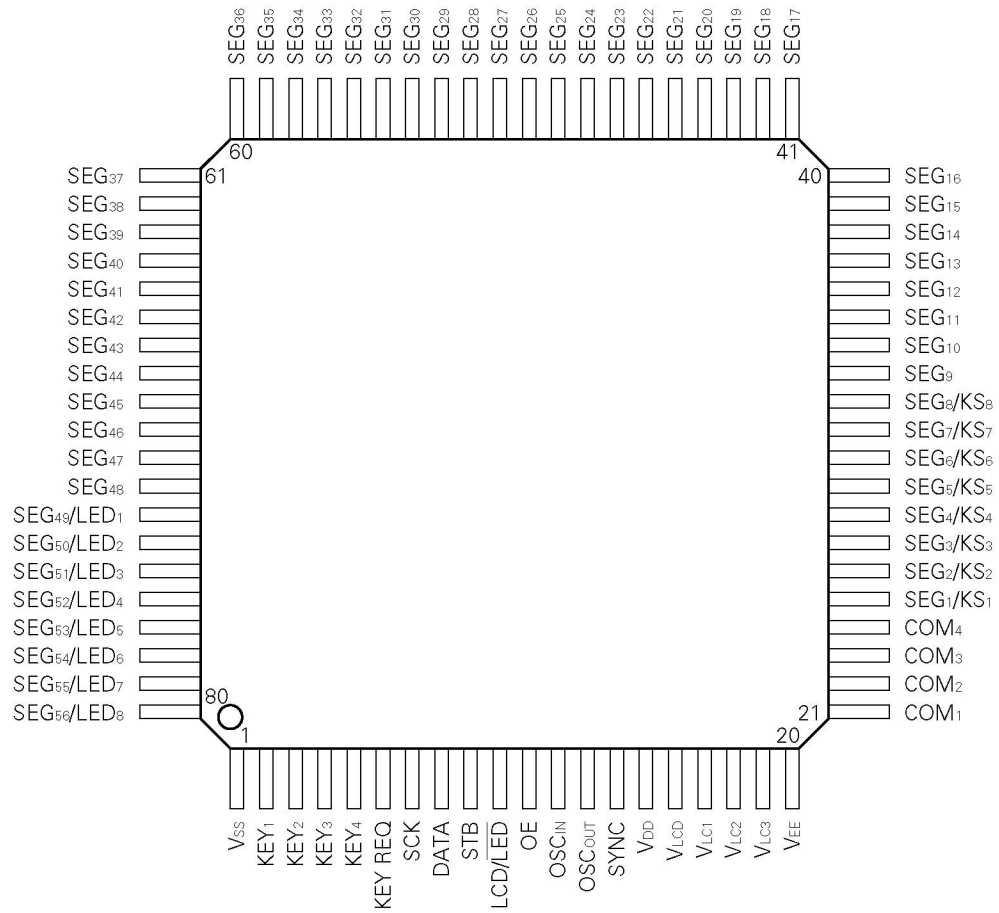

Note Though V_{SS} and V_{EE} are internally connected, be sure to connect all the power supply pins (V_{DD}, V_{SS}, V_{LCD}, and V_{EE}).

PIN FUNCTIONS

Symbol	Name	No.	Description
SEG ₁ /KS ₁ to SEG ₈ /KS ₈	Segment output/key source output	25 to 32	These pins serve as LCD segment output pins and key source output pins for key scanning.
SEG ₉ to SEG ₄₈	Segment output	33 to 72	LCD segment output pins
SEG ₄₉ /LED ₁ to SEG ₅₆ /LED ₈	Segment output/LED output pins	73 to 80	These pins can be used as LCD segment output or LED output pins depending on the setting of the LCD/ $\overline{\text{LED}}$ pin.
COM ₁ to COM ₄	Common output	21 to 24	LCD common output pins
SCK	Shift clock input	7	Data shift clock. Data is read at the rising edge, and is output at the falling edge of this clock.
DATA	Data input/output	8	This pin inputs a command or display data, or outputs key data. A command or data is input at the rising edge of the shift clock, starting from the most significant bit. Key data is output at the falling edge of the shift clock, starting from the most significant bit. This pin serves as an open-drain pin in the output mode.
STB	Strobe input	9	Data can be input when this signal goes low. When it goes high, command processing is performed.
LCD/ $\overline{\text{LED}}$	LCD/LED select	10	When this signal goes high, the SEG _n /LED _m pins function as LCD segment output pins; when it goes low, they function as LED driver output pins. The LED driver has a drive capability of 15 mA and is N-ch open drain.
OE ^{Note}	Output enable input	11	When this signal goes low, all the segment output and LED output pins are off (SEG _n = COM _n = V _{LCD}). Internal data are saved.
OSC _{IN}	Oscillation input	12	Connect a resistor for oscillation circuit across these pins.
OSC _{OUT}	Oscillation output	13	
SYNC	Synchronizing signal	14	A synchronizing signal input pin. When two or more μ PD16431A's are used, each device is wired-ORed. This pin must be pulled up when this chip is used alone.
KEY ₁ to KEY ₄	Key data input	2 to 5	Key data input pins for key scanning
KEY REQ	Key request output	6	This signal goes high when a key is pressed (key data = H). Read the key data only while this pin is high.
V _{DD}	Logic power supply	15	Power supply pin for internal logic
V _{SS}	Logic GND	1	GND pin for internal logic and LED output
V _{LCD}	LCD drive power supply	16	Power supply pin for LCD drive
V _{EE}	LCD GND	20	GND pin for LCD drive
V _{LC1} to V _{LC3}	Power supply for LCD drive	17 to 19	Power supply for driving dot matrix LCD

Note At OE = L, the key data cannot be written correctly, even when the display ON/OFF of the status command is set to the "normal operation" (10). Also, in this state, unnecessary waveforms are generated from between SEG₁/KS₁ to SEG₈/KS₈ during the key scanning period. (The display is OFF.)

CONFIGURATION OF SHIFT REGISTER

Two shift registers, an 8-bit command register and a 56-bit display register, are provided. The first 8 bits of input data are recognized as a command and are sent to the command register, and the 9th bit and those that follow are recognized as display data and are sent to the display register.

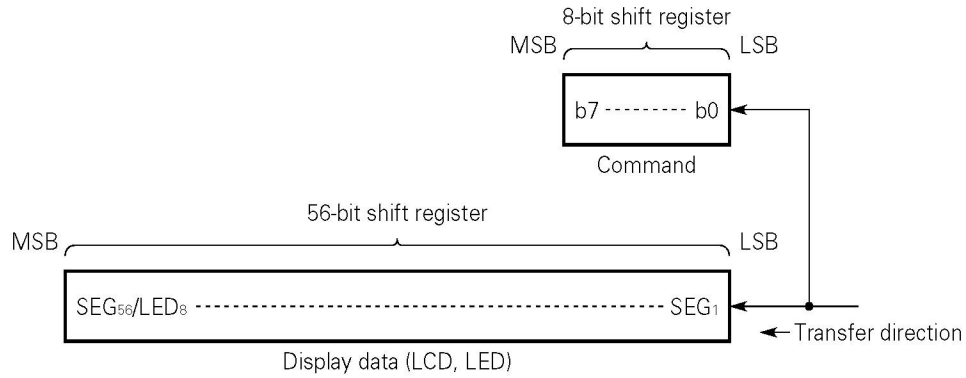

The meaning of the display data is as follows:

LCD: 0 → off, 1 → on

LED: 0 → on, 1 → off

Be sure to transfer 56 bits of display data.

CONFIGURATION OF OUTPUT LATCH

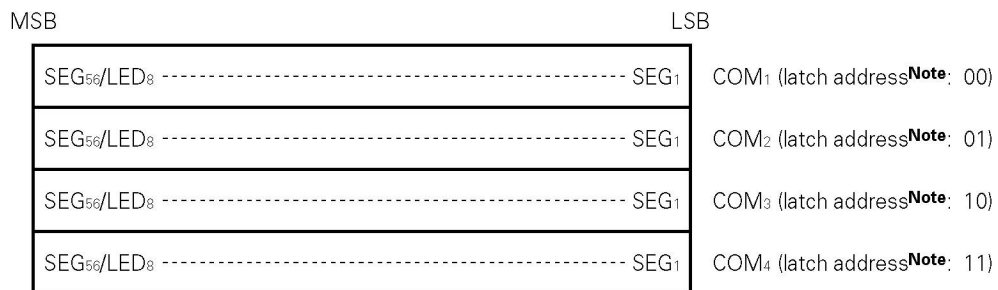

Note Bits b3 and b4 of status command (Refer to page 8.)

KEY MATRIX CONFIGURATION

An example of key matrix configurations is shown below.

1) When pressing three or more times is assumed:

A configuration example is shown below. In this configuration, 0 to 32 ON switches can be recognized.

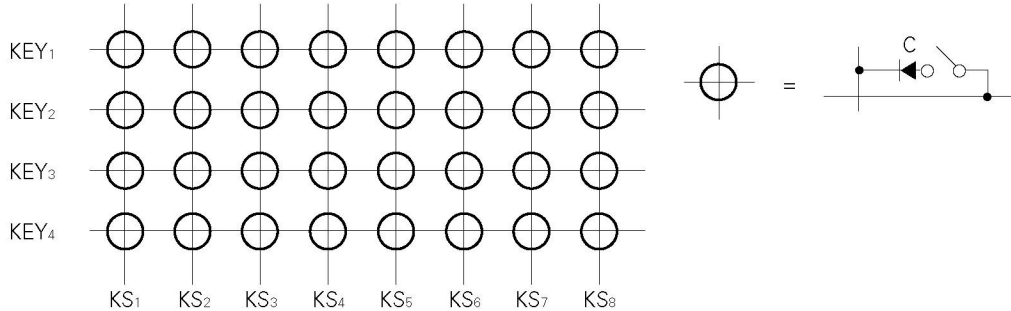

2) When pressing twice or more times is assumed:

A configuration example is shown below. In this configuration, 0 to 2 ON switches can be recognized.

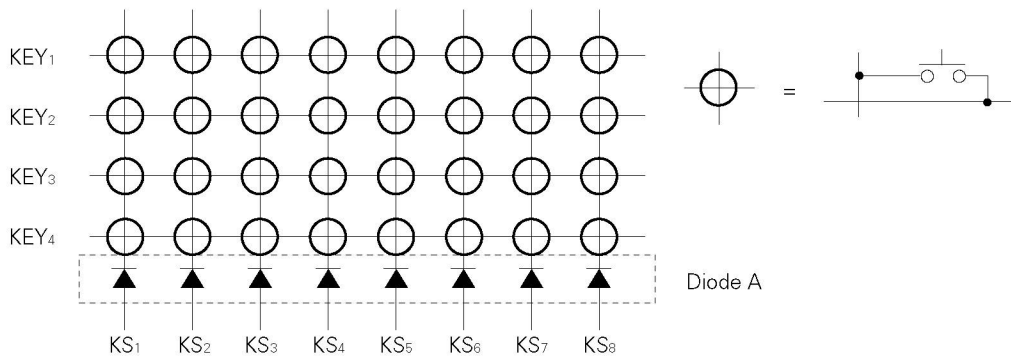

In this configuration, pressing three or more times may cause OFF switches to be determined to be ON.

For example, if SW2 to SW4 are ON and KS1 has been selected (high level) as shown below, SW3 in which current I1 is running is supposed to be detected to be ON. However, since SW2 and SW4 are ON, current I2 runs thus resulting in SW1 to be recognized as being ON.

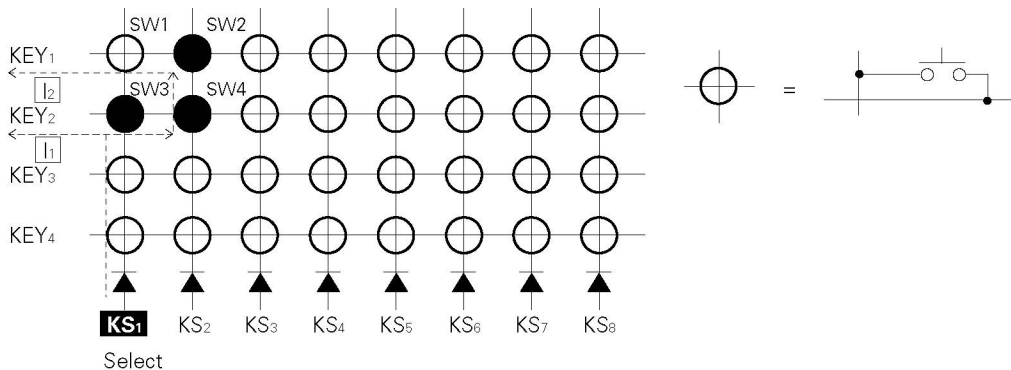

If diode A is not available, not only the key data may not be read normally but the LCD display may be affected or ICs may be damaged or deteriorated.

For example, if SW1 and SW2 are ON and KS1 has been selected (high level) as shown below, this will cause not only current I1 which is supposed to run but also short-circuited current I2 of KS1 to KS2 to run. It is possible that this will then cause the following three problems:

- (1) Since the level to KEY₂ is not correctly sent, the key data cannot be latched correctly.
- (2) If KS₂ is used as SEG₂ as well, the LCD display may be distorted (such as causing unintended segments to light up).
- (3) Since the short-circuited current (current I₂) of KS₂ (high level) to KS₂ (low level) runs, ICS may be damaged or deteriorated

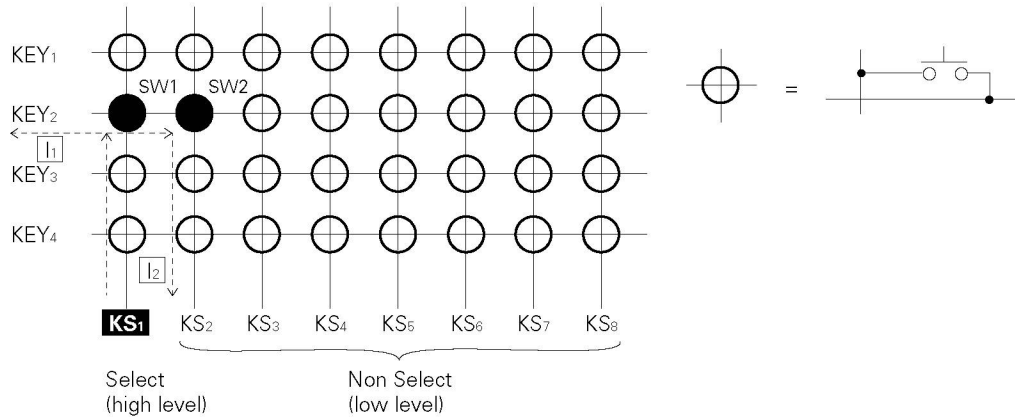

CONFIGURATION OF KEY DATA LATCH

The key data is latched as illustrated below and is read by a read command, starting from the most significant bit. Key data is read once a frame and latched when coinciding with the immediately preceding data. In other words, it requires at least 2 frames from the time the key is pressed till data is confirmed to be the key data (the key request becoming H).

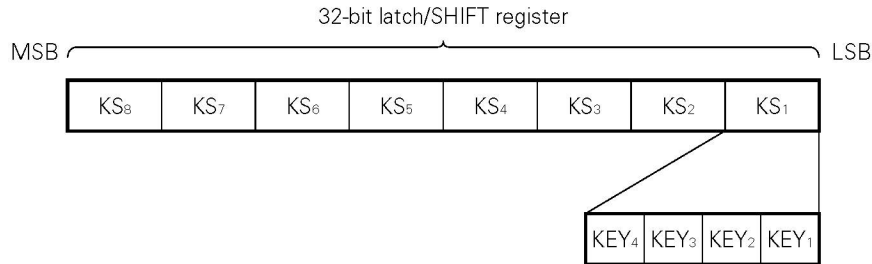

The key data is 0 when off and 1 when on.

KEY INPUT EQUIVALENT CIRCUIT

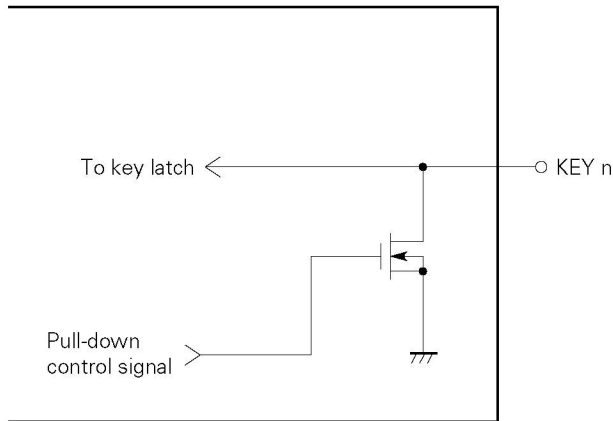

- The pull-down control signal goes high only during key source output and turns on the pull-down transistor.
- The on-resistance of the pull-down transistor is several kΩ.

(2) Status command

This command sets a data write/read mode, turns on/off display, and sets a latch address.

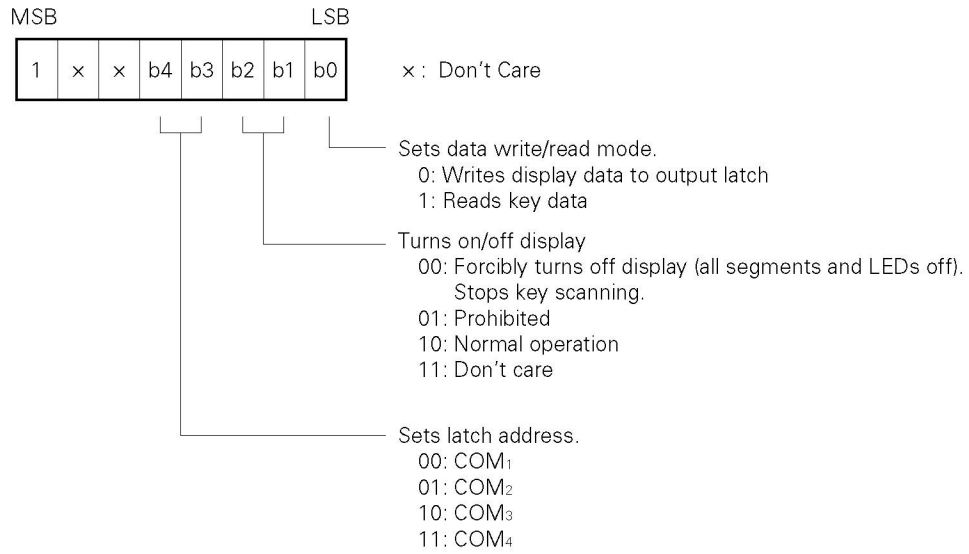

Values when power is applied

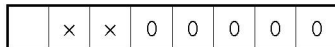

OUTPUT SELECT VOLTAGE

1. COM

	+	-	Bias
When selected	V _{LCD} V _{LCD}	GND GND	1/2 bias
When not selected	1/2 V _{LCD} V _{LC2}	1/2 V _{LCD} V _{LC2}	
When key scanned	1/2 V _{LCD} V _{LC2}	1/2 V _{LCD} V _{LC2}	
When selected	V _{LCD} V _{LCD}	GND GND	1/3 bias
When not selected	1/3 V _{LCD} V _{LC3}	2/3 V _{LCD} V _{LC1}	
When key scanned	1/2 V _{LCD} V _{LC2}	1/2 V _{LCD} V _{LC2}	

Top : with internal power supply
Bottom: with external power supply

2. SEG

	+	-	Bias
When selected	GND GND	V _{LCD} V _{LCD}	1/2 bias
When not selected	V _{LCD} V _{LCD}	GND GND	
When key scanned	GND GND	V _{LCD} V _{LCD}	
When key not scanned	V _{LCD} V _{LCD}	GND GND	
When selected	GND GND	V _{LCD} V _{LCD}	1/3 bias
When not selected	2/3 V _{LCD} V _{LC1}	1/3 V _{LCD} V _{LC3}	
When key scanned	GND GND	V _{LCD} V _{LCD}	
When key not scanned	V _{LCD} V _{LCD}	GND GND	

OUTPUT WAVEFORM
(1) 1/2 duty (1/2 dias)

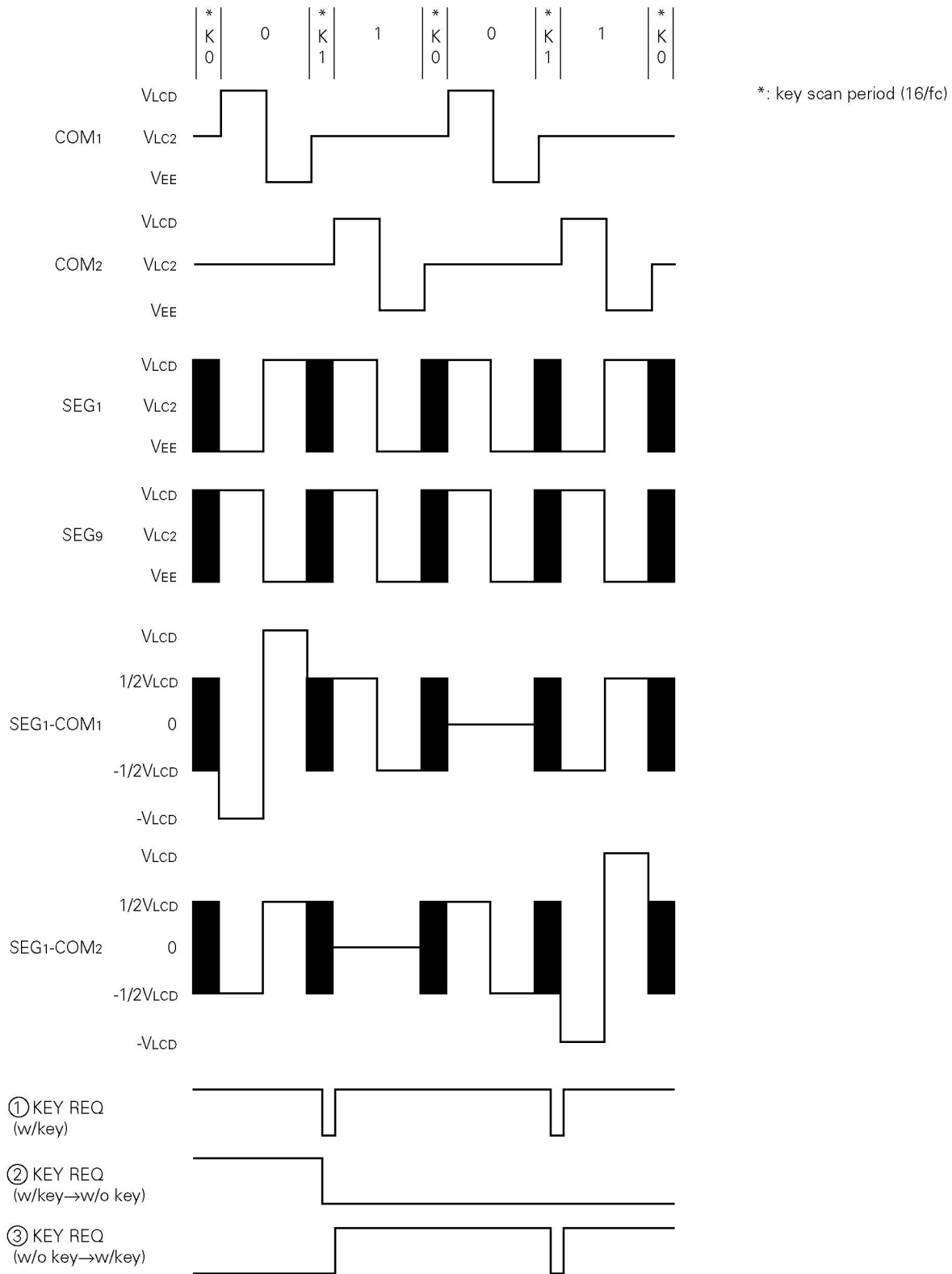

KEY SCAN PERIOD (K0) EXPANSION

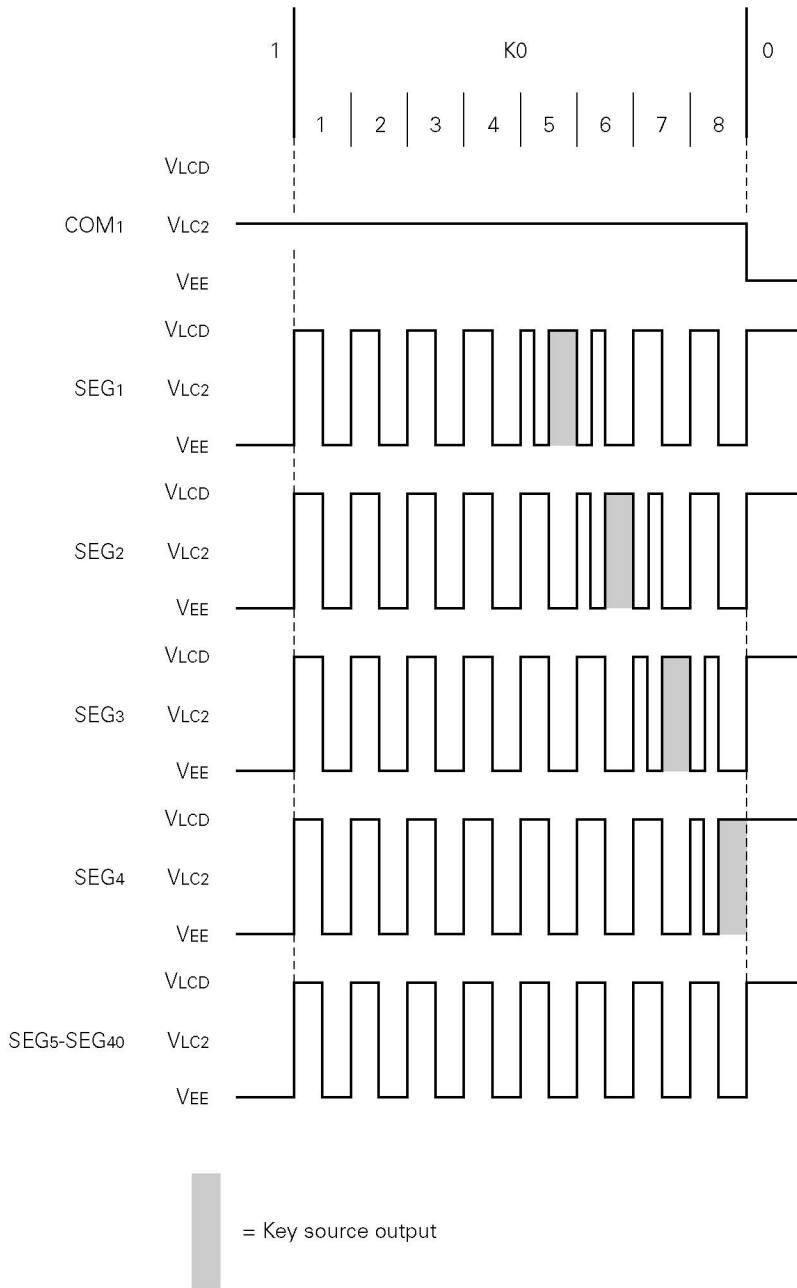

KEY SCAN PERIOD (K1) EXPANSION

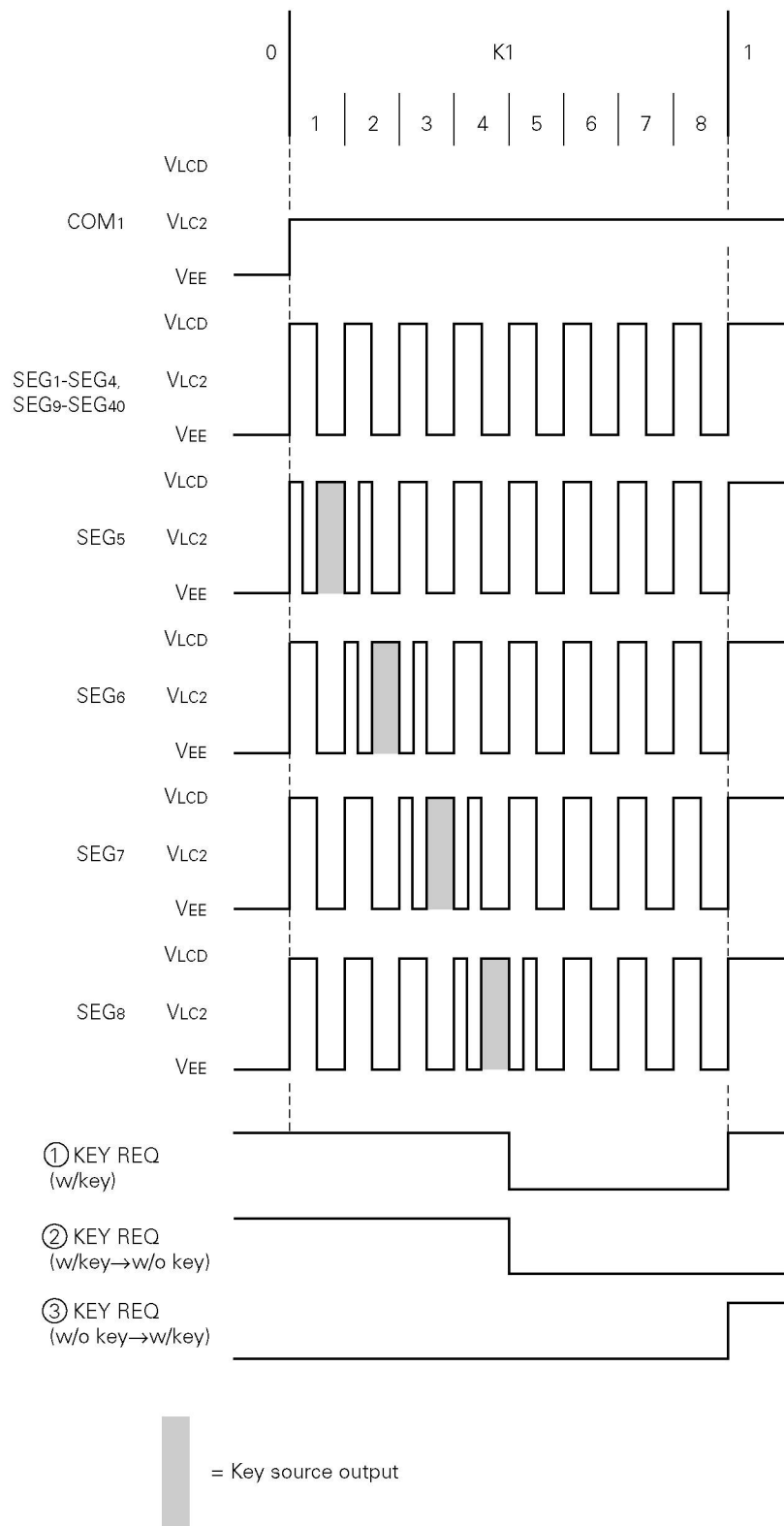

(2) 1/3 duty (1/3 bias)

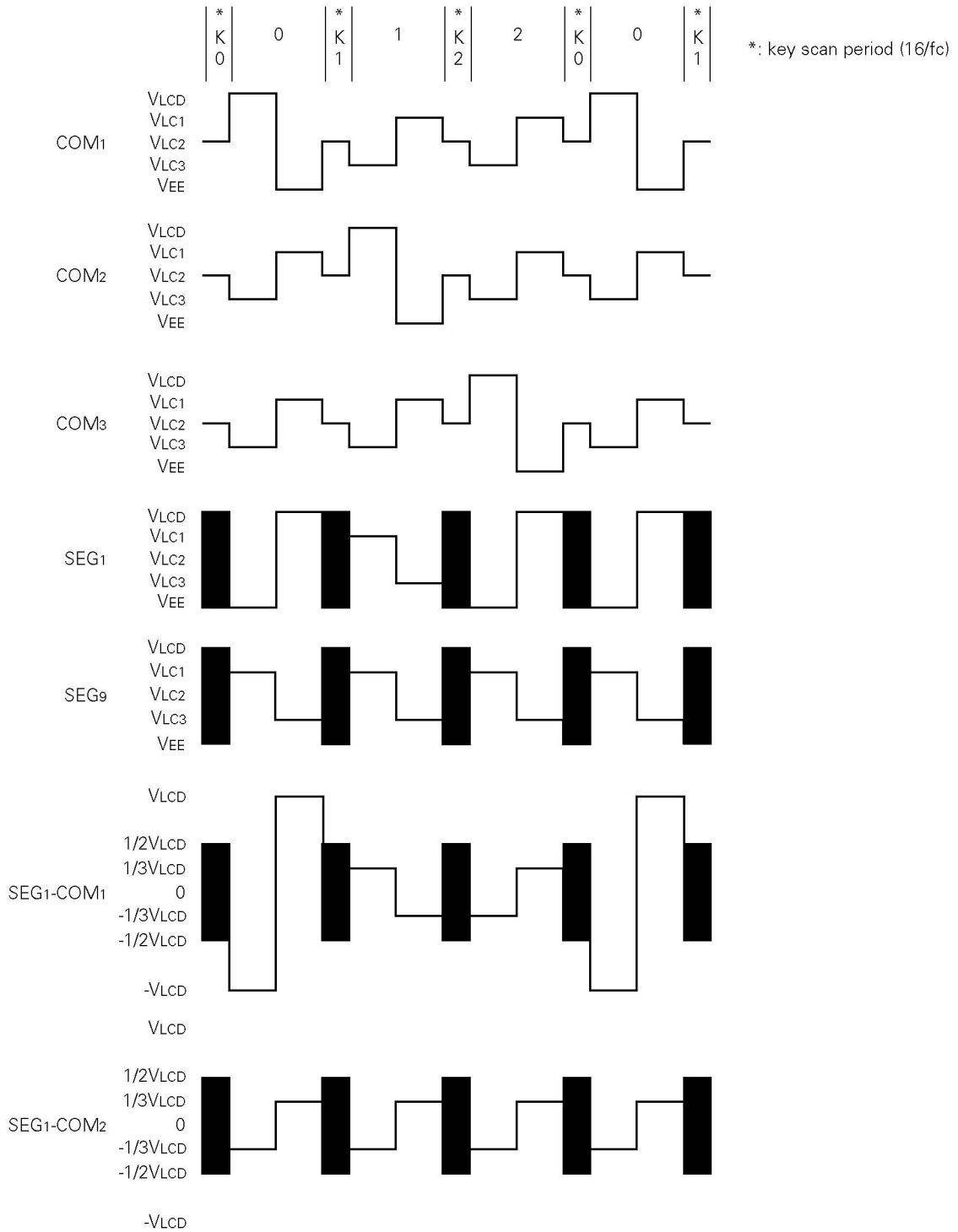

KEY SCAN PERIOD (K0) EXPANSION

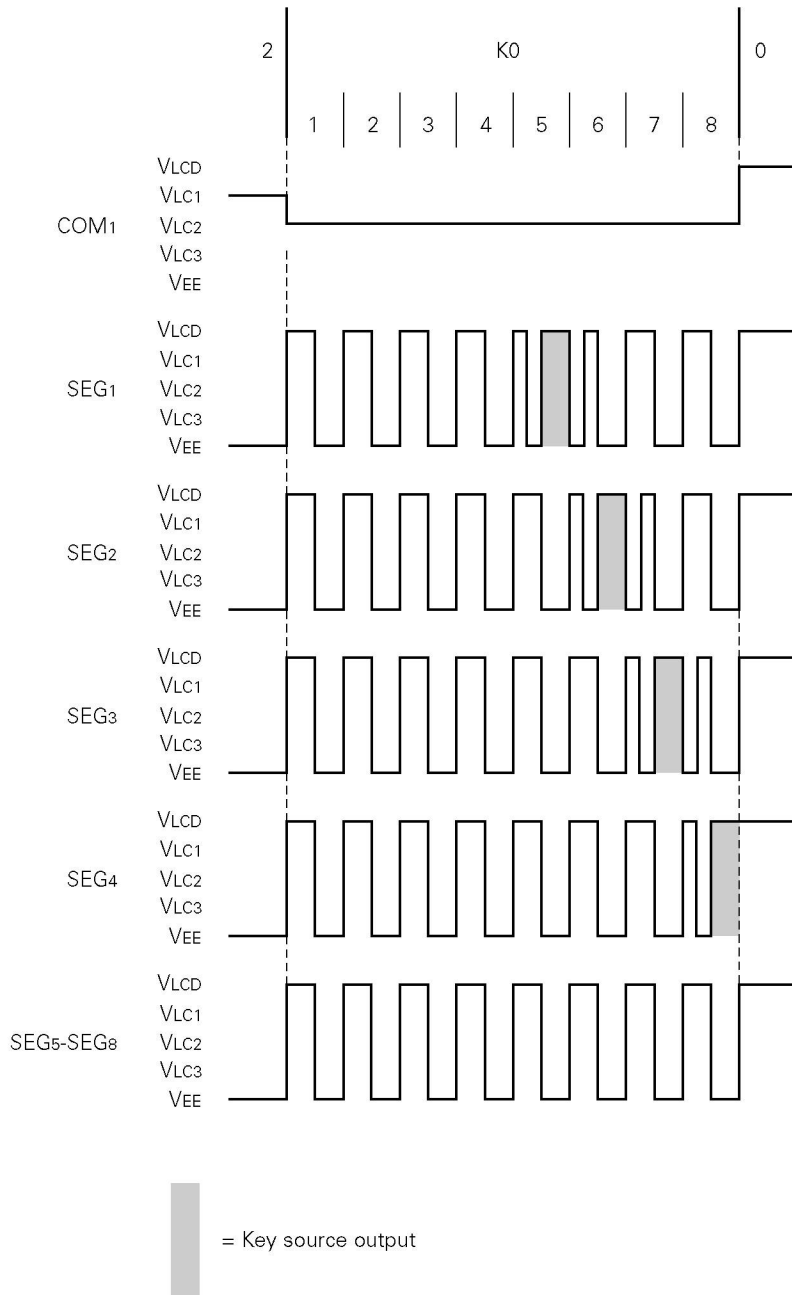

KEY SCAN PERIOD (K1) EXPANSION

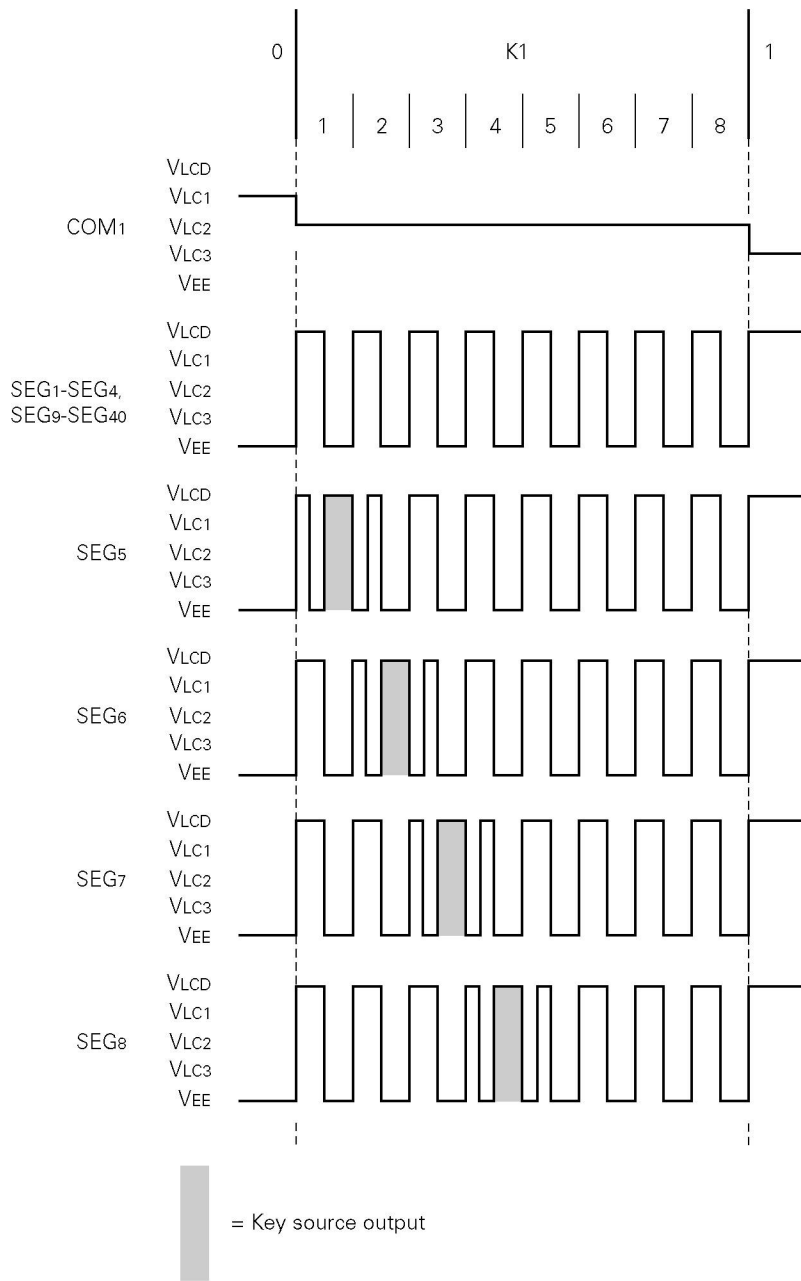

(3) 1/4 duty (1/3 bias)

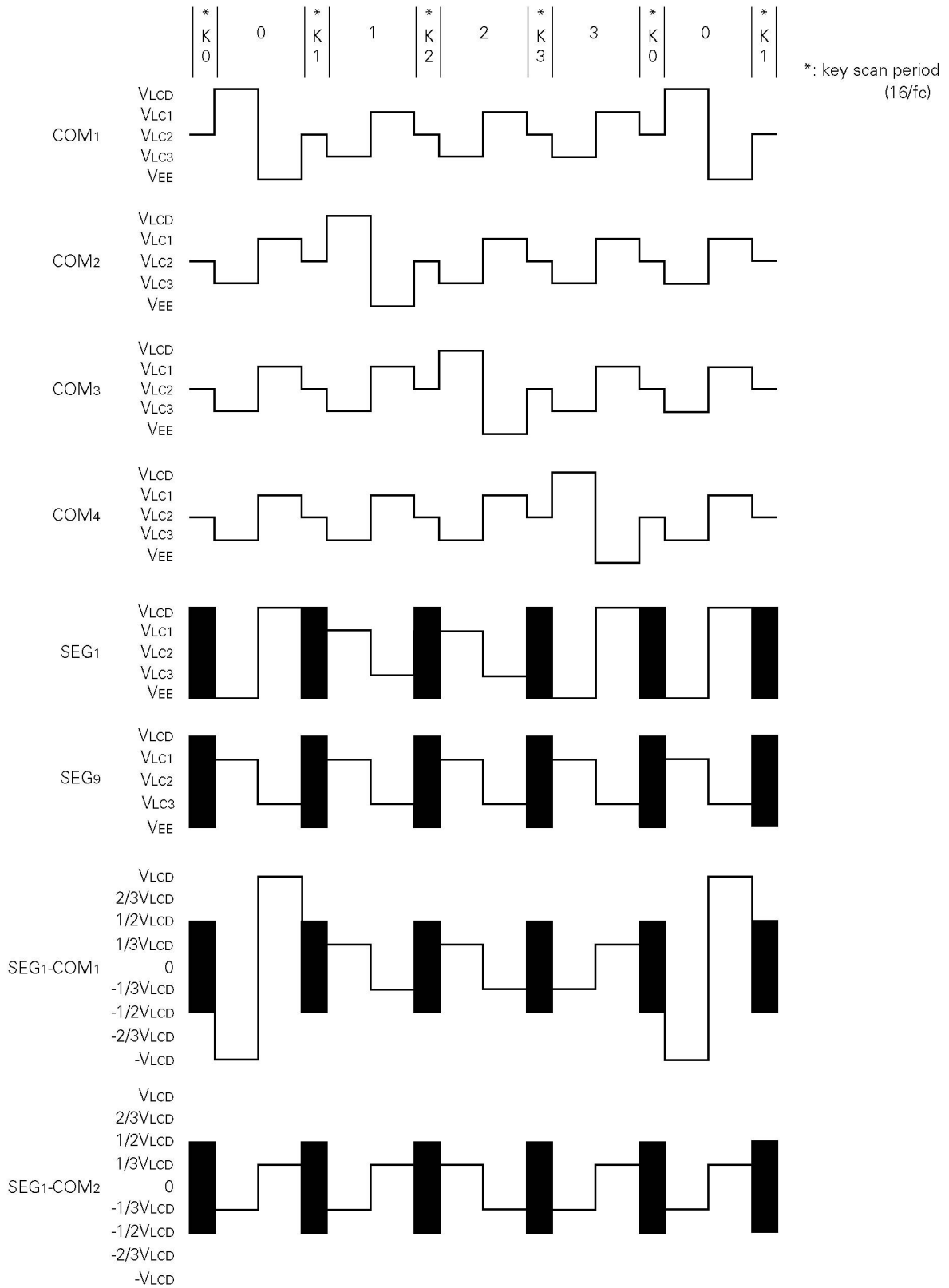

KEY SCAN PERIOD (K0) EXPANSION

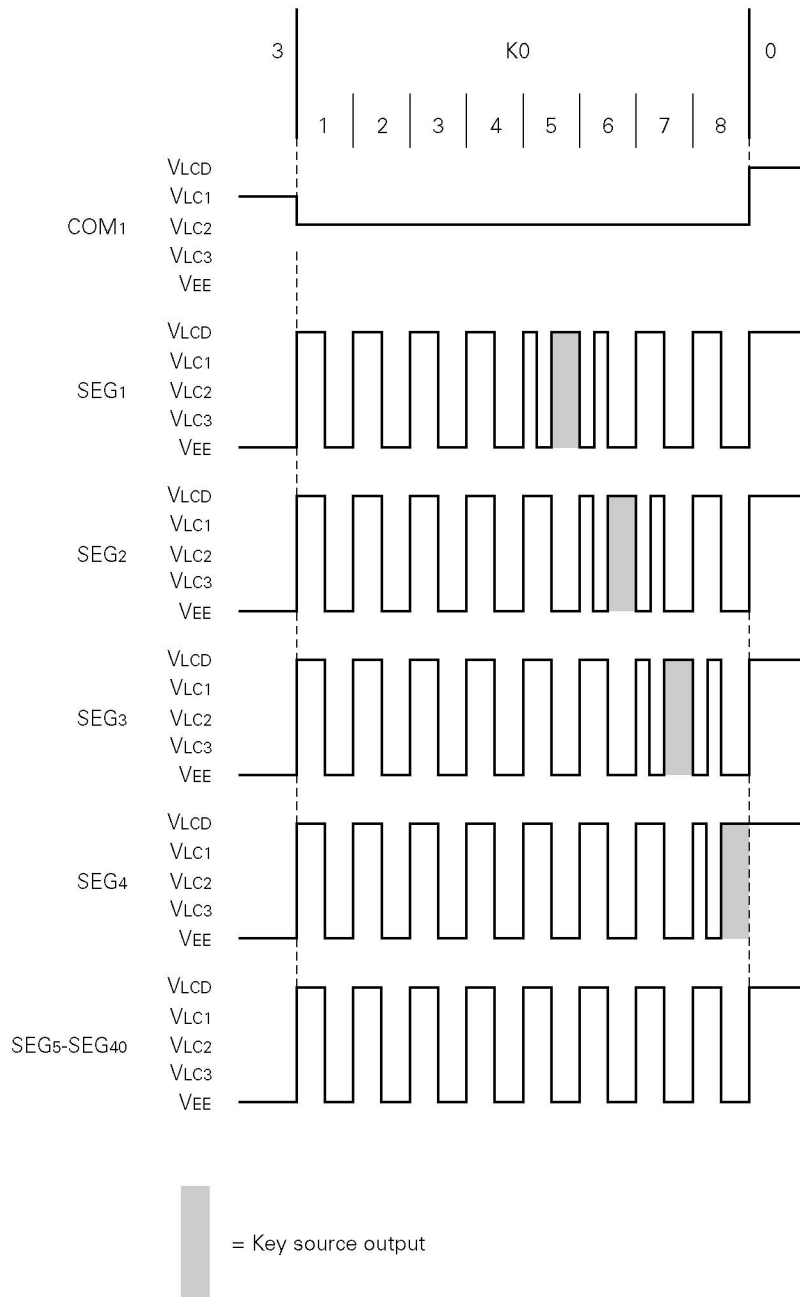

KEY SCAN PERIOD (K1) EXPANSION

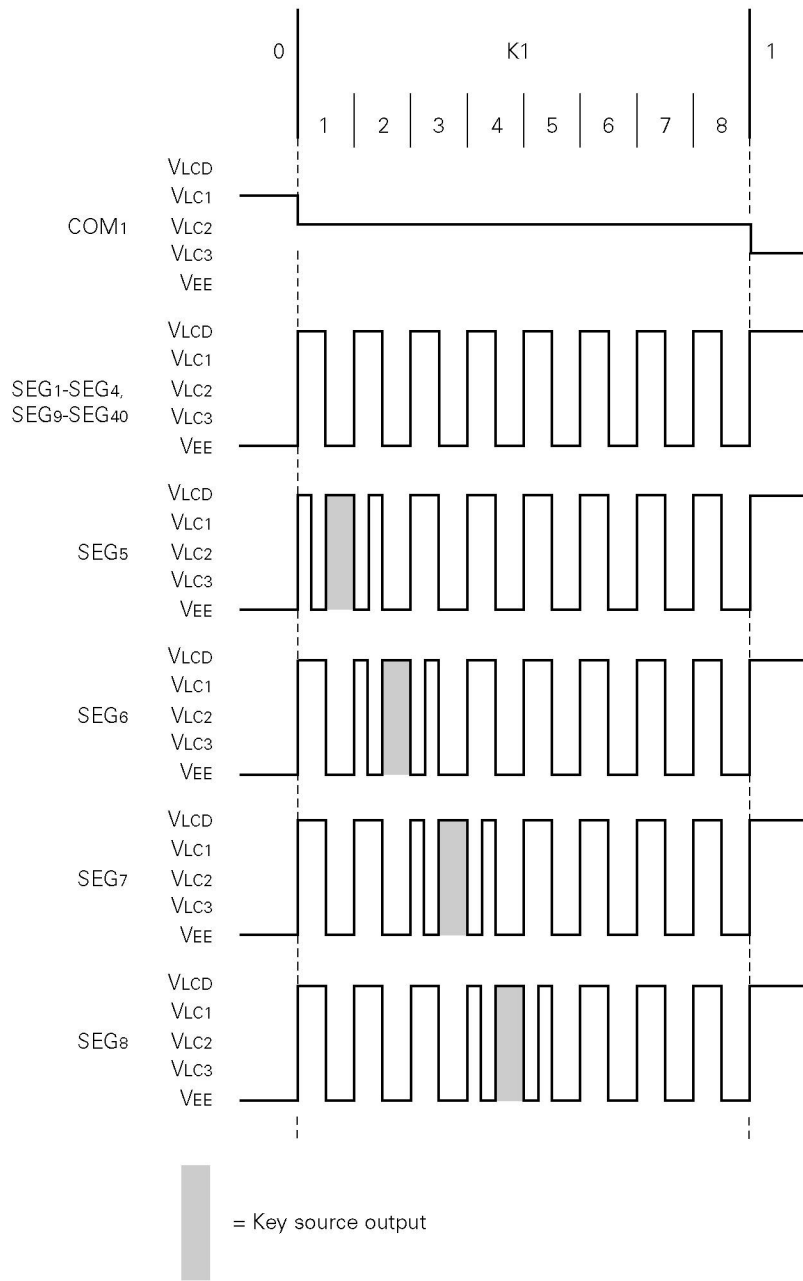

KEY SCAN PERIOD (K2) EXPANSION

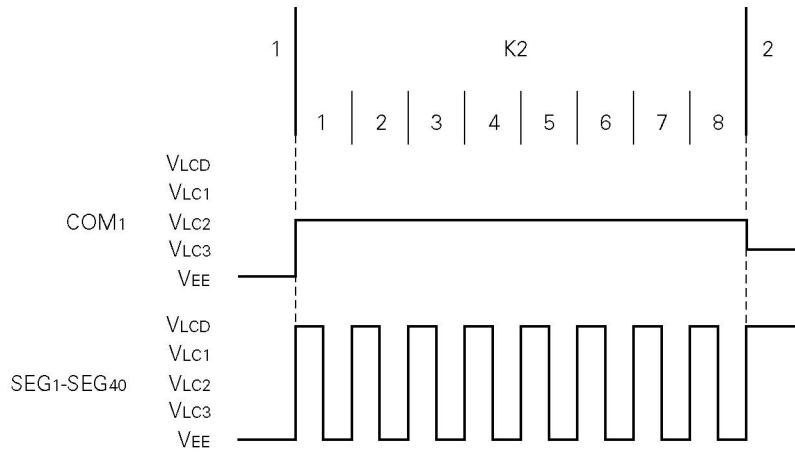

KEY SCAN PERIOD (K3) EXPANSION

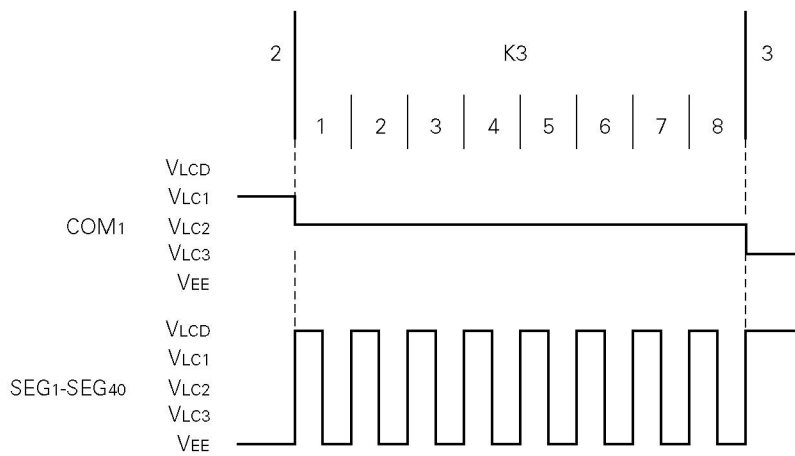

SERIAL COMMUNICATION FORMAT

(1) Receive (command/data write)

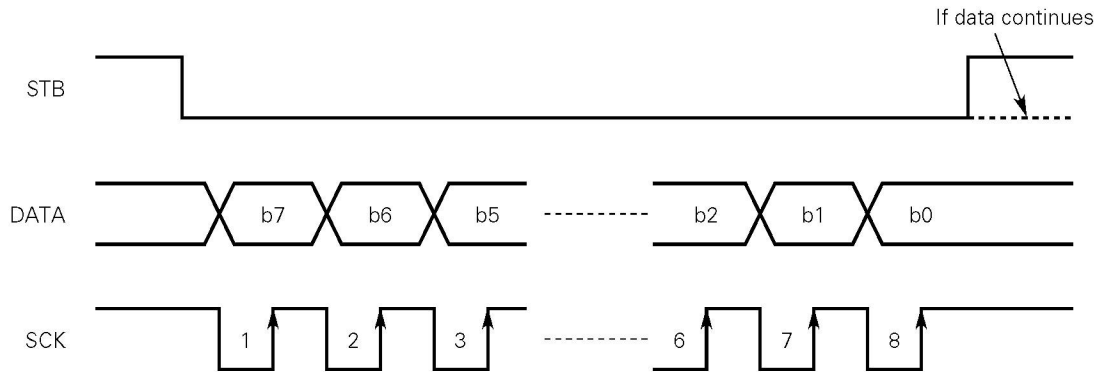

(2) Transmit (command/data read)

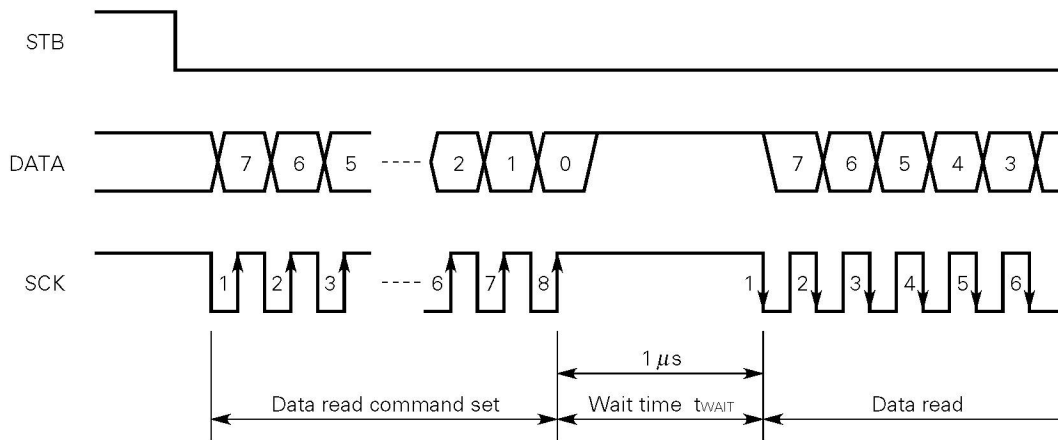

Note Because the DATA pin is an N-ch open-drain output pin, be sure to connect an external pull-up resistor to this pin (1 kΩ to 10 kΩ).

APPLICATION

1. Example of initial setting + display data write

Parameter	STB	Command/data								Remarks
		b7	b6	b5	b4	b3	b2	b1	b0	
Start	H									
Set display command	L	0	0	0	0	0	0	0	0	1/4 duty, frame frequency = $f_{osc}/128 \times 1/4$, internal drive voltage, master
	H									
Status command	L	1	0	0	0	0	0	0	0	Display data write, display off, latch address: COM ₁
Display data 1	L	x	x	x	x	x	x	x	x	} COM ₁ data (7 bytes)
⋮	⋮									
Display data 7	L	x	x	x	x	x	x	x	x	
	H									
Status command	L	1	0	0	0	1	0	0	0	Display data write, display off, latch address: COM ₂
Display data 1	L	x	x	x	x	x	x	x	x	} COM ₂ data (7 bytes)
⋮	⋮									
Display data 7	L	x	x	x	x	x	x	x	x	
	H									
Status command	L	1	0	0	1	0	0	0	0	Display data write, display off, latch address: COM ₃
Display data 1	L	x	x	x	x	x	x	x	x	} COM ₃ data (7 bytes)
⋮	⋮									
Display data 7	L	x	x	x	x	x	x	x	x	
	H									
Status command	L	1	0	0	1	1	0	0	0	Display data write, display off, latch address: COM ₄
Display data 1	L	x	x	x	x	x	x	x	x	} COM ₄ data (7 bytes)
⋮	⋮									
Display data 7	L	x	x	x	x	x	x	x	x	
	H									
Status command	L	1	0	0	0	0	1	0	0	Display data write, display on
End	H									

2. Example of display data write (rewrite, 1/4)

Parameter	STB	Command/data								Remarks
		b7	b6	b5	b4	b3	b2	b1	b0	
Start	H									
Status command	L	1	0	0	0	0	1	0	0	Display data write, display on, latch address: COM ₁
Display data 1	L	x	x	x	x	x	x	x	x	} COM ₁ data (7 bytes)
⋮	⋮									
Display data 7	L	x	x	x	x	x	x	x	x	
	H									
Status command	L	1	0	0	0	1	1	0	0	Display data write, display on, latch address: COM ₂
Display data 1	L	x	x	x	x	x	x	x	x	} COM ₂ data (7 bytes)
⋮	⋮									
Display data 7	L	x	x	x	x	x	x	x	x	
	H									
Status command	L	1	0	0	1	0	1	0	0	Display data write, display on, latch address: COM ₃
Display data 1	L	x	x	x	x	x	x	x	x	} COM ₃ data (7 bytes)
⋮	⋮									
Display data 7	L	x	x	x	x	x	x	x	x	
	H									
Status command	L	1	0	0	1	1	1	0	0	Display data write, display on, latch address: COM ₄
Display data 1	L	x	x	x	x	x	x	x	x	} COM ₄ data (7 bytes)
⋮	⋮									
Display data 7	L	x	x	x	x	x	x	x	x	
End	H									

3. Example of key data read

Parameter	STB	Command/data								Remarks
		b7	b6	b5	b4	b3	b2	b1	b0	
KEY REQ check										KEY REQ = H: Key data exists. → Start reading. KEY REQ = L: Key data does not exist (reading is inhibited). → Check KEY REQ again.
Start	H									
Status command	L	1	0	0	0	0	1	0	1	Data read, display on
Wait time	L									1 μs
Key data 1 ⋮ Key data 4	L ⋮ L	x	x	x	x	x	x	x	x	} 4 bytes
End	H									

ABSOLUTE MAXIMUM RATINGS (T_a = 25 °C, V_{ss} = 0 V)

Parameter	Symbol	Ratings	Unit
Logic supply voltage	V _{DD}	-0.3 to +7.0	V
Logic input voltage	V _{IN}	-0.3 to V _{DD} + 0.3	V
Logic output voltage (DATA)	V _{OUT}	-0.3 to +7.0	V
LCD drive supply voltage	V _{LCD}	-0.3 to +7.0	V
LCD drive supply input voltage	V _{LC1} to V _{LC3}	-0.3 to V _{LCD} + 0.3	V
Driver output voltage (segment, common, LED)	V _{OUT2}	-0.3 to V _{LCD} + 0.3	V
LED output current	I _o	+20	mA
Operating ambient temperature	T _{opt}	-40 to +85	°C
Storage temperature	T _{stg}	-55 to +150	°C
Permissible package power dissipation	P _r	1 000	mW

RECOMMENDED OPERATING CONDITIONS

Parameter	Symbol	MIN.	TYP.	MAX.	Unit
Logic supply voltage	V _{DD}	2.7	5.0	5.5	V
LCD drive supply voltage	V _{LCD}	V _{DD}	5.0	6.5	V
Logic input voltage	V _{IN}	0		V _{DD}	V
Driver output voltage	V _{LC1} to V _{LC3}	0		V _{LCD}	V

ELECTRICAL SPECIFICATIONS (Unless otherwise specified, T_a = -40 to +85 °C, V_{DD} = V_{LCD} = 5 V ±10%)

Parameter	Symbol		MIN.	TYP.	MAX.	Unit
Input voltage, high	V _{IH}		0.7 V _{DD}		V _{DD}	V
Input voltage, low	V _{IL}		0		0.3 V _{DD}	V
Input current, high	I _{IH}	CLK, STB, LCD/ $\overline{\text{LED}}$, OE			1	μA
Input current, low	I _{IL}	CLK, STB, LCD/ $\overline{\text{LED}}$, OE			-1	μA
Output voltage, low	V _{OL1}	LED ₁ to LED ₈ , I _{OL1} = 15 mA			1.0	V
Output voltage, high	V _{OH2}	OSC _{OUT} , I _{OH2} = -1 mA	0.9 V _{DD}			V
Output voltage, low	V _{OL2}	DATA, OSC _{OUT} , SYNC, I _{OL2} = 4 mA			0.1 V _{DD}	V
Leakage current, high	I _{LOH2}	DATA, SYNC, V _{IN OUT} = V _{DD}			1	mA
Leakage current, low	I _{LOL2}	DATA, SYNC, V _{IN OUT} = V _{SS}			-1	mA
Common output ON resistance	R _{COM}	COM ₁ to COM ₄ , I _O = 100 μA			2.4	kΩ
Segment output ON resistance	R _{SEG}	SEG ₁ to SEG ₆₆ , I _O = 100 μA			4.0	kΩ
Logic current dissipation	I _{DD}	f _{OSC} = 250 kHz			250	μA
LCD drive current consumption	I _{LCD}	With internal bias and no load			500	μA

Remark The TYP. value is a reference value at T_a = 25 °C.

SWITCHING CHARACTERISTICS

(Unless otherwise specified, $T_a = -40$ to $+85$ °C, $V_{DD} = V_{LCD} = 5\text{ V} \pm 10\%$, $R_L = 5\text{ k}\Omega$, $C_L = 150\text{ pF}$)

Parameter	Symbol	Conditions	MIN.	TYP.	MAX.	Unit
Oscillation frequency	f_{osc}	$R = 100\text{ k}\Omega$	175	250	325	kHz
Oscillation frequency	f_{osc}	$R = 200\text{ k}\Omega$	105	150	195	kHz
Propagation delay time	t_{PZL}	SCK ↓ → DATA ↓			100	ns
Propagation delay time	t_{PLZ}	SCK ↓ → DATA ↑			300	ns
SYNC delay time	t_{DSYNC}				1.5	μs

TIMING REQUIREMENTS

(Unless otherwise specified, $T_a = -40$ to $+85$ °C, $V_{DD} = V_{LCD} = 5\text{ V} \pm 10\%$, $R_L = 5\text{ k}\Omega$, $C_L = 150\text{ pF}$)

Parameter	Symbol	Conditions	MIN.	TYP.	MAX.	Unit
Clock frequency	f_c	OSC _{IN} external clock	50		325	kHz
High-level clock pulse width	t_{WHC}	OSC _{IN} external clock	1.5		16	μs
Low-level clock pulse width	t_{WLC}	OSC _{IN} external clock	1.5		16	μs
Shift clock cycle	t_{CYK}	SCK	900			ns
High-level shift clock pulse width	t_{WHK}	SCK	400			ns
Low-level shift clock pulse width	t_{WLK}	SCK	400			ns
Shift clock hold time	t_{HSTBK}	STB ↓ → SCK ↓	1.5			μs
Data setup time	t_{DS}	DATA → SCK ↑	100			ns
Data hold time	t_{DH}	SCK ↑ → DATA	200			ns
STB hold time	t_{DKSTB}	SCK ↑ → STB ↑	1			μs
STB pulse width	t_{WSTB}		1			μs
Wait time	t_{WAIT}	CLK ↑ → CLK ↓	1			μs
SYNC removal time	t_{SREM}		250			ns

Output Load

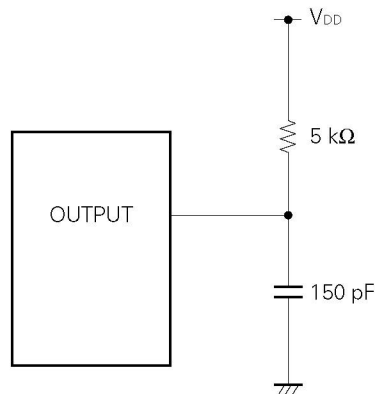

Switching Characteristic Waveform

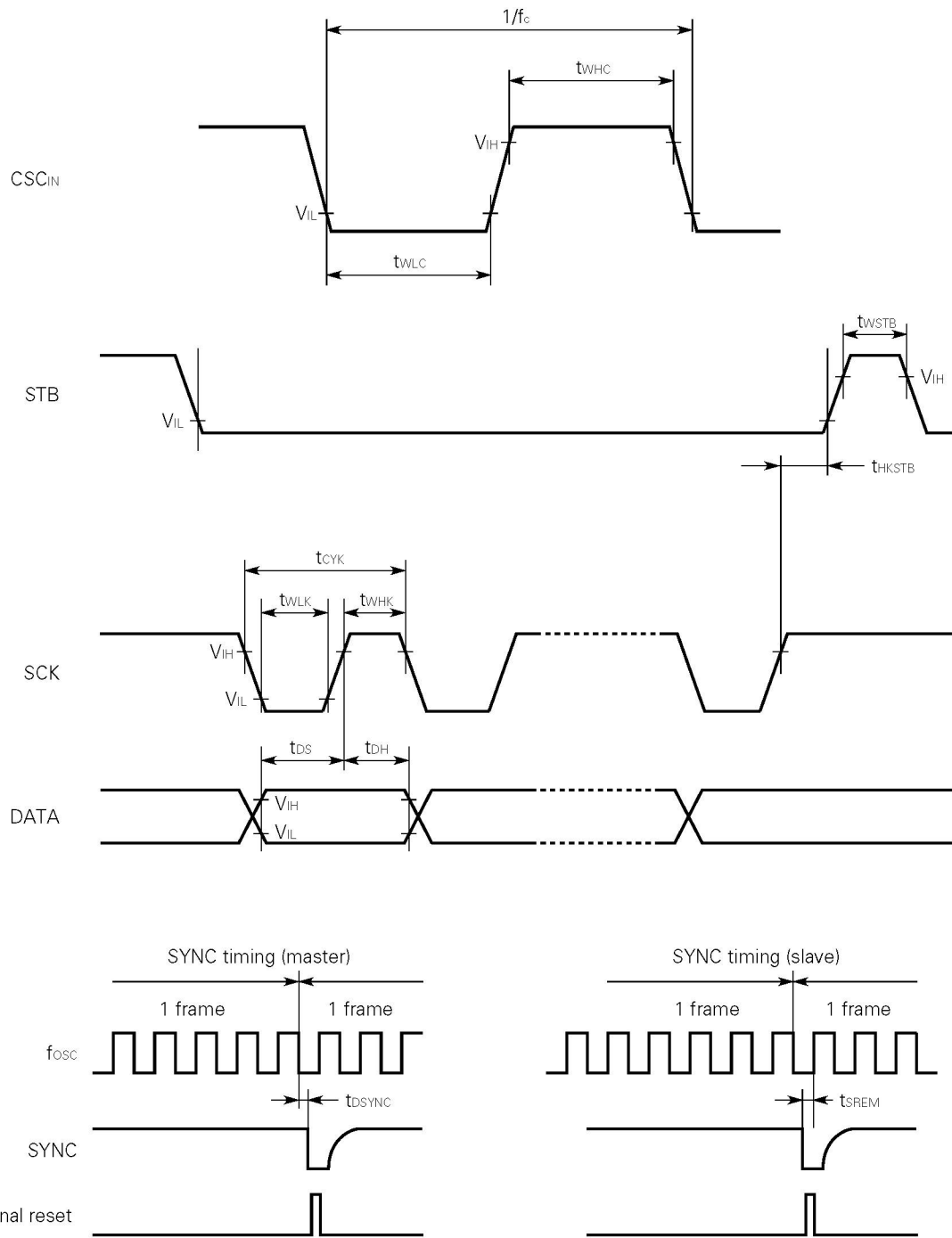

Switching Characteristic Waveform

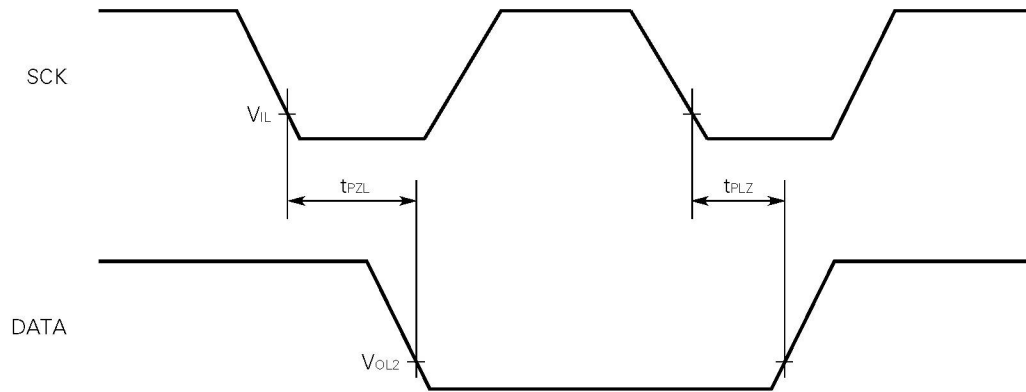

Application Circuit Example (with LED, 1/4 duty, 1/3 bias)

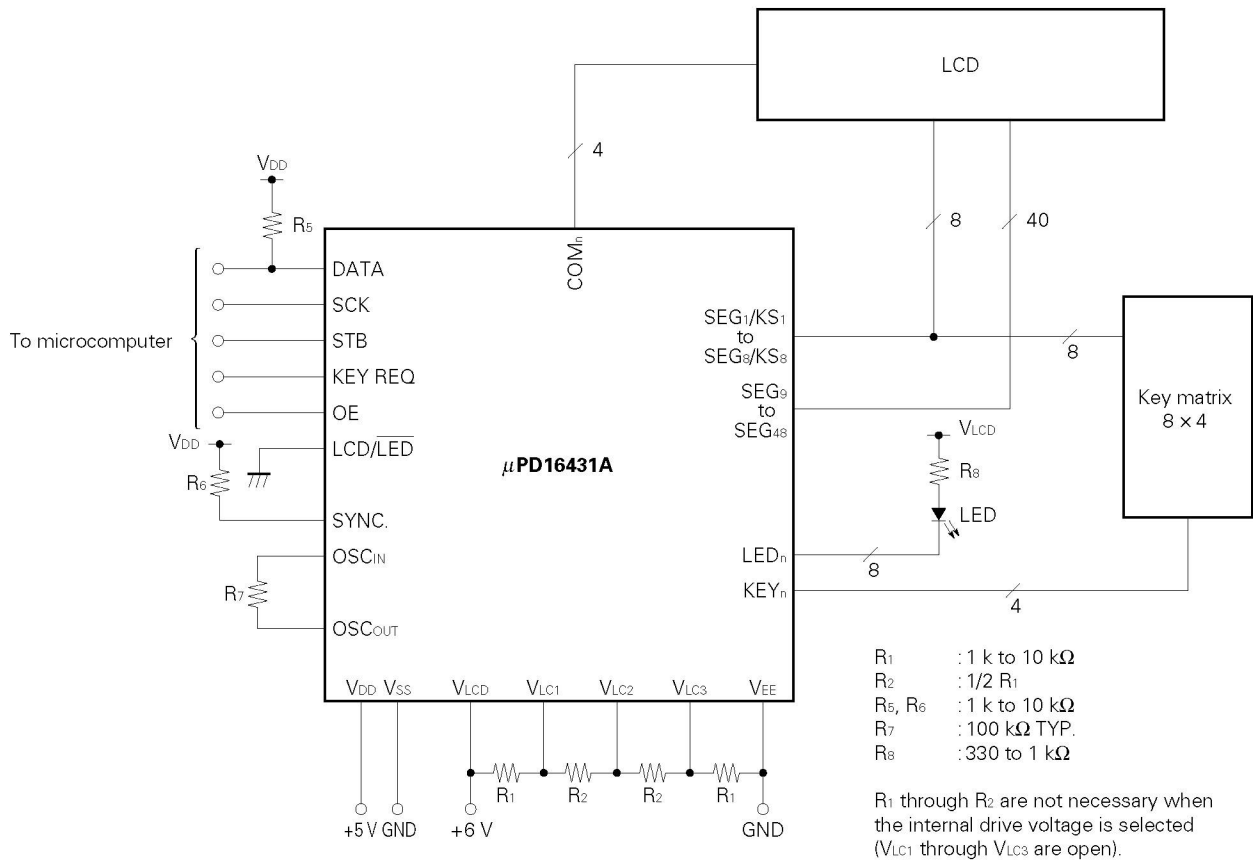

80 PIN PLASTIC LQFP (□14)

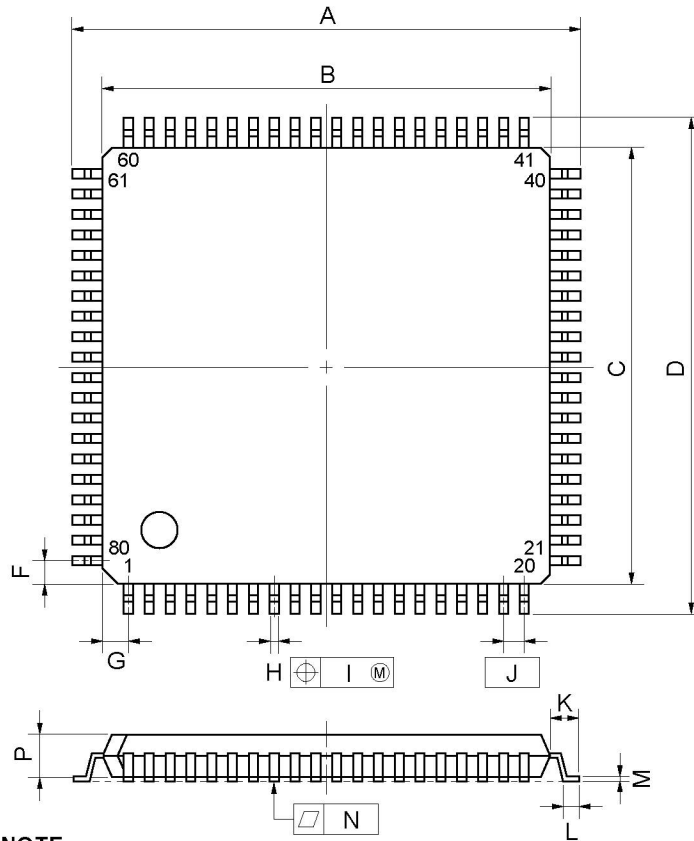

detail of lead end

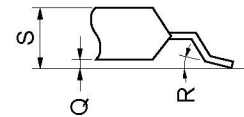

NOTE

Each lead centerline is located within 0.13 mm (0.005 inch) of its true position (T.P.) at maximum material condition.

ITEM	MILLIMETERS	INCHES
A	16.0±0.2	0.630±0.008
B	14.0±0.1	0.551 ^{+0.005} _{-0.004}
C	14.0±0.1	0.551 ^{+0.005} _{-0.004}
D	16.0±0.2	0.630±0.008
F	0.825	0.032
G	0.825	0.032
H	0.30±0.10	0.012 ^{+0.004} _{-0.005}
I	0.13	0.005
J	0.65 (T.P.)	0.026 (T.P.)
K	1.0±0.2	0.039 ^{+0.009} _{-0.008}
L	0.5±0.2	0.020 ^{+0.008} _{-0.009}
M	0.125 ^{+0.10} _{-0.05}	0.005 ^{+0.004} _{-0.002}
N	0.10	0.004
P	1.4±0.1	0.055±0.004
Q	0.125±0.075	0.005±0.003
R	3° ^{+7°} _{-3°}	3° ^{+7°} _{-3°}
S	1.7 MAX.	0.067 MAX.

S80GC-65-7ET-1

REFERENCE

Document Name	Document No.
NEC Semiconductor Device Reliability/Quality Control System	IEI-1212
Quality grade on NEC Semiconductor Devices	IEI-1209

No part of this document may be copied or reproduced in any form or by any means without the prior written consent of NEC Corporation. NEC Corporation assumes no responsibility for any errors which may appear in this document.

NEC Corporation does not assume any liability for infringement of patents, copyrights or other intellectual property rights of third parties by or arising from use of a device described herein or any other liability arising from use of such device. No license, either express, implied or otherwise, is granted under any patents, copyrights or other intellectual property rights of NEC Corporation or others.

While NEC Corporation has been making continuous effort to enhance the reliability of its semiconductor devices, the possibility of defects cannot be eliminated entirely. To minimize risks of damage or injury to persons or property arising from a defect in an NEC semiconductor device, customer must incorporate sufficient safety measures in its design, such as redundancy, fire-containment, and anti-failure features.

NEC devices are classified into the following three quality grades:

“Standard”, “Special”, and “Specific”. The Specific quality grade applies only to devices developed based on a customer designated “quality assurance program” for a specific application. The recommended applications of a device depend on its quality grade, as indicated below. Customers must check the quality grade of each device before using it in a particular application.

Standard: Computers, office equipment, communications equipment, test and measurement equipment, audio and visual equipment, home electronic appliances, machine tools, personal electronic equipment and industrial robots

Special: Transportation equipment (automobiles, trains, ships, etc.), traffic control systems, anti-disaster systems, anti-crime systems, safety equipment and medical equipment (not specifically designed for life support)

Specific: Aircrafts, aerospace equipment, submersible repeaters, nuclear reactor control systems, life support systems or medical equipment for life support, etc.

The quality grade of NEC devices in “Standard” unless otherwise specified in NEC's Data Sheets or Data Books. If customers intend to use NEC devices for applications other than those specified for Standard quality grade, they should contact NEC Sales Representative in advance.

Anti-radioactive design is not implemented in this product.